

Training to compete TLM3

1. When we had divided the cake into parts, some more guests arrived, so we had to divide each part into four parts. There are 16 people now. How many parts did we initially have?



- a) 2 b) 3 c) 4 d) 5 e) 6

2. How many positive divisors has the number obtained multiplying the figures of 1997?

- a) 2 b) 4 c) 5 d) 10 e) 20

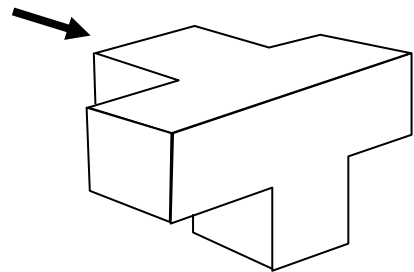
3. Look at the object. Which of the following views can be seen from where the arrow indicates?

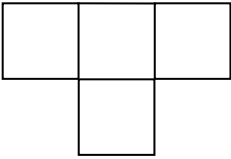
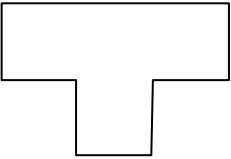

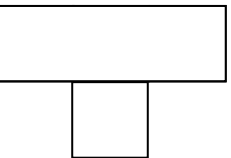
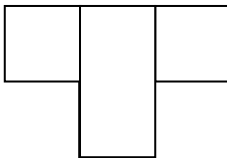
- a)  b) 
- c)  d)  e) 

4. What is the proportion between the figures of M and W in the picture?

- a) $\frac{10}{13}$ b) $\frac{5}{7}$ c) $\frac{5}{6}$ d) $\frac{7}{10}$ e) $\frac{3}{4}$

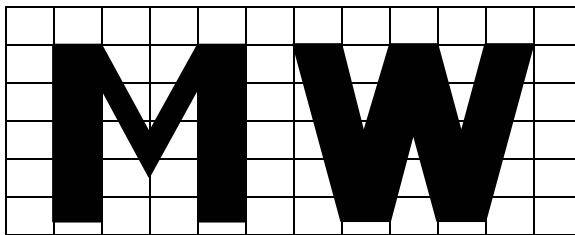

5. An equilateral triangle and a regular hexagon are inscribed in the same circle. The quotient of the hexagon area and the triangle area is:

- a) 1'5 b) 2 c) 3 d) 4 e) 5

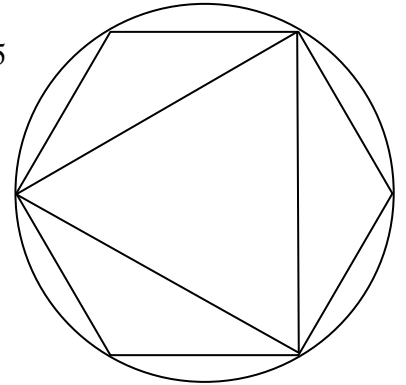

6. The element of the sequence were written according to some rule.

1 2 4 7 28 33 X X

Replace the X marks by:

- A. 188; 195 B. 99; 273 C. 198; 205 D. 40; 47 E. 192; 199

7. Which set make on the axis is the set of solution of the inequality

$$(x+1)^2 \geq x^2 + 4x - 3 ?$$

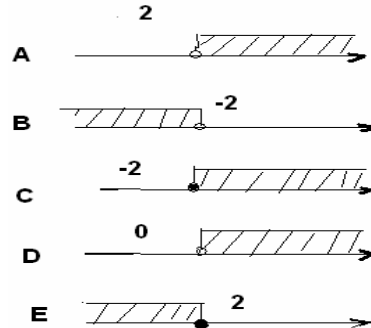

8. Find a two-digit number, whose second digit is 20% bigger than the first one?

- A. 23 B. 35 C. 57 D. 56

9. A domestic helper is 2258 mm tall with his arm up. To clean the ceiling he has four feather dusters; each of different length. Which duster is long enough to reach the ceiling that is 3 meters high?

- A) 50 cm; B) 0,00008 km; C) 8 dm; D) 400 mm.

10. What brand of olive oil is cheaper? (1 litre of olive oil weighs 900 grams)

- A) 8 €dm³; B) 8 €kg; C) 600 €quintal; D) 6000 €m³

11. Which mass of gold is more expensive?

- A) 0,4 grams; B) 0,20 grams; C) 0,0100 grams; D) 0,200 grams

12. A table, measured with a tape, is 82 cm. high. A glass, measured with a precision gauge is 8,75 cm high, and it was put on the table. How high is the rim of the glass from the floor? (Choose the more accurate measurement possible to determine with the given data)
 A) 82 cm; B) 91 cm; C) 90,75 cm; D) 90 cm
13. A rectangular floor has sides of 3,25 m and 4,05 m. Which surface is the most accurate to obtain from the given data?
 A) 13,2 m²; B) 13 m²; C) 13,1625 m²; D) 14,6 m²
14. In a map with scale 1:100000 the distance between two cities is 10 cm. What is the distance between the same two cities in a map with scale 1: 250000?
 A) 2,5 cm B) 4 cm C) 6,25 cm D) 25 cm
15. What is the probability that an integer number of the group $\{1,2,3,\dots,100\}$ is divisible by 2 but not divisible by 3?
 A) $\frac{1}{6}$ B) $\frac{33}{100}$ C) $\frac{17}{50}$ D) $\frac{18}{25}$
16. The value x is in inverse ratio to the square of y. We know that if $x = 10$ then $y = 2$. What value of x corresponds to $y = 1$?
 A) 5 B) 20 C) 40 D) $\frac{1}{5}$
17. In a village $\frac{1}{3}$ of the children can swim, $\frac{2}{3}$ can ride a bicycle and $\frac{1}{7}$ can both swim and ride a bicycle. We know that there are fewer than 40 children, how many of them can neither swim nor ride a bicycle?
 A) 3 B) 4 C) 5 D) 6
18. A comb for horses has 100 teeth, each is 1 mm wide. The gaps between the teeth are also 1 mm wide. How long is the comb?
 A) 9,9 cm B) 19 cm C) 19,9 cm D) 20 cm
19. Think a number, double it, then add 3. Multiply your answer by 4 and take away 5. Now take away the number you have first thought of. No matter what the first number was, your answer will be a multiple of:
 A) 2 B) 3 C) 5 D) 7
20. At a table there are ten people to celebrate a birthday. How many cheers are shouted if everyone shouts with each other once?
 A) 100 B) 47 C) 50 D) 45
21. A shop-keeper raises of 20% the prices marked on his goods. Then with a notice he makes a 20% discount on the marked prices. What discount did he make on the original prices?
 A) 4% B) 10% C) no discount D) 20%

22. What is $\frac{1}{2}$ of $\frac{2}{3}$ of $\frac{3}{4}$ of $\frac{4}{5}$ of a Euro ?
 A) 1 cent B) 20 cents C) 50 cents D) 10 cents
23. A society is composed of 40 members, 24 men and 16 women. Four men and two women wear glasses. Calculate the probability that a man without glasses is randomly selected.
 A) $\frac{2}{5}$ B) $\frac{3}{5}$ C) $\frac{1}{10}$ D) $\frac{1}{2}$
24. A square sheet of paper is divided equally in half, in this way we get a rectangle that has a perimeter of 18 cm. The surface of the square, in cm^2 , is:
 A) 9 B) 12 C) 24 D) 36

25. Shown in the figure there is a cube whose side is 12 cm. long. One ant is moving on the surface of the cube from the vertex A to the vertex B along the path as shown in the figure. How long is the distance run by the ant?

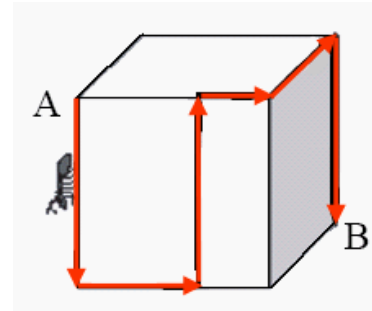

- A) 50 cm. B) 60 cm.
 C) 55 cm. D) 65 cm.
26. A ship travels in a certain direction at 20 miles an hour and comes back at 30 miles an hour thanks to the favourable wind; what is its medium speed in miles an hour?
 A) 25 B) 22 C) 24 D) 26
27. On a sphere of radius 1 a circumference is drawn with a compass with a spread of 1. What is the length of this circumference?
 A) $\frac{3}{2}\pi$ B) $\sqrt{3}\pi$ C) 2π D) $2\sqrt{3}\pi$
28. Here is a series of inequalities written by a student, where is the mistake?
 a) $x > 2$; b) $2x > 4$; c) $2x - x^2 > 4 - x^2$; d) $x(2-x) > (2-x)(2+x)$; e) $x > 2+x$; f) $0 > 2$.
 A) $b \rightarrow c$ B) $c \rightarrow d$ C) $d \rightarrow e$ D) $e \rightarrow f$
29. If $f(f(x)) = 4x - 3$ we can obtain:
 A) $f(x) = -2x + 3$ B) $f(x) = -4x + 1$ C) $f(x) = 2x - 3$ D) $f(x) = 2\sqrt{x} - 3$
30. A cyclist runs a slope at a constant speed v and goes down in the same road with a still constant speed, but equal to the triple of the previous one. The medium speed of the whole trip is:
 A) $\frac{4}{3}v$ B) $\frac{3}{2}v$ C) $2v$ D) it depends from the length of the road.

31. A ship in a seaport has got an iron staircase along its side; 8 steps emerge from the water at a distance of 30 cm from each other. During the night the tide rises 1.5 m. How many steps remain out of the water?
 A) 3 B) 8 C) 4 D) We don't know.
32. The sum of two numbers is equal to 18, the sum of their inverses is $\frac{1}{4}$. What are the two numbers?
 A) I have not enough data B) 10 ; 8 C) 14 ; 4 D) 12 ; 6
33. In a bag there are 24 sweets of 6 different types with the same number for each type. What is the smallest number of sweets that you have to pick out to have surely at least two equal sweets?
 A) 4 B) 5 C) 6 D) 7
34. The geometric locus of the points of the plane equidistant from the point P(0,2) and from the straight line of the equation $y=-2$ is
 A) It doesn't exist B) $y = \frac{1}{8}x^2$ C) it's the point (0,0) D) $y = -\frac{1}{8}x^2$
35. The geometric locus of the points of the plane of the second quadrant whose ordinate exceeds the abscissa by 2 is :
 A) A straight line B) a half-line C) An empty set D) A segment
36. A box contains three red balls, four green balls and five blue balls. If you take out two balls after having put in to the box the first, the probability that no green ball comes out is:
 A) $\frac{8}{12}$ B) $\frac{64}{144}$ C) $\frac{56}{132}$ D) $\frac{5^4}{12^4 * 4^4}$
37. Find the maximum value that the expression
 MATE+MA+TICA
 can have, when each letter corresponds to a number, so different letters correspond to different numbers:
 A) 18438 B) 17630 C) 18538 D) 18536
38. Two pillars, respectively 30 and 60 meters tall have been placed vertically on a horizontal plane at a certain distance one from the other. A straight cable links the top of each pillar with the base the other. How high is the intersection point of the two cables?
 A) 10 m. B) 15 m. C) 20 m. D) 25 m.